

Environmental Spill Containment

- Spill Platform Systems
- Drum Stacking Systems
- Outdoor Drum Storage Buildings
- Drum Work Stations
- Drum Over Packs & Salvage Drums
- Spill Kits & Accessories
- Emergency Spill Control Applicators





Modular Spill Containment Platform System

FEATURES

These platforms can be arranged in an endless number of configurations

The modular platforms feature a low profile for easier loading and unloading and are compatible with Eagle's 1689 ramp

30 gallon spill capacity per 2 drum side

Blow molded high density polyethylene construction for superior strength

Removable poly grating

New design includes forklift pockets & flat top grading

2 & 4 Drum Budget Basins add low cost spill protection to your work place with our budget basins. Drums rest on the floor of the sump with a 61/2" high sidewall

NEW Design!



MODEL # 1632 - 2 DRUM
30 GALLON SPILL CAPACITY

MODEL # 1634 - 4 DRUM
60 GALLON TOTAL SPILL CAPACITY
30 GALLONS PER SIDE

MODEL # 1633 - 1 DRUM
12 GALLON SPILL CAPACITY



MODEL #1638
4 DRUM BUDGET BASIN
66 GALLON SPILL
CAPACITY

MODEL # 1631
2 DRUM BUDGET BASIN
34 GALLON
SPILL CAPACITY

MODEL	DESCRIPTION	DIMENSIONS	WEIGHT	LOAD CAPACITY
1631	2-DRUM BUDGET BASIN	261/4" X 511/2" X 61/2"	20 LBS.	5,000 LBS.
1632	2-DRUM MODULAR PLATFORM	261/4" X 511/2" X 61/2"	32 LBS.	5,000 LBS.
1633	1-DRUM MODULAR PLATFORM	26" X 26" X 61/2"	16 LBS.	2,000 LBS.
1634	4-DRUM MODULAR PLATFORM	521/2" X 511/2" X 61/2"	65 LBS.	10,000 LBS.
1638	4-DRUM BUDGET BASIN	511/2" X 511/2" X 7"	25 LBS.	5,000 LBS.
1689	POLY RAMP FOR 1632, 1633, 1634	451/2" X 32" X 8"	32 LBS.	1,500 LBS.
1689BLK	BLACK POLY RAMP FOR 1632, 1633, 1634	451/2" X 32" X 8"	32 LBS.	1,500 LBS.

MODEL # 1632
BATTERY STORAGE

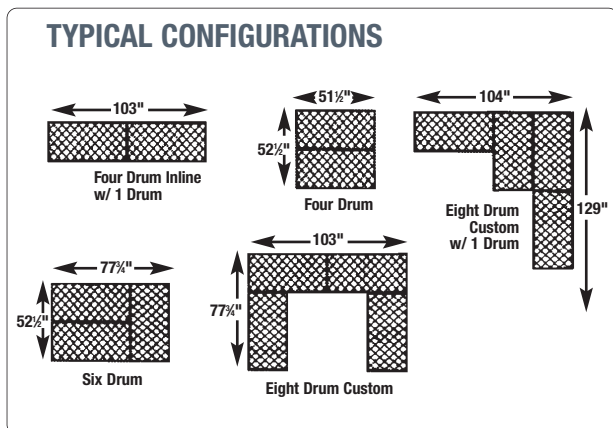
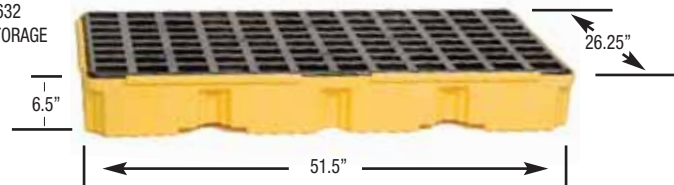

CONVENIENT
STORAGE CENTER



Spill Containment Platforms

FEATURES

Low profile for easy access

Polyethylene construction for excellent chemical resistance

Grating with 1 3/4" square opening that removes easily for cleaning

Are compatible with our Model 1689 ramp

Meet EPA requirements for secondary spill containment of hazardous materials (40 CFR 264.175)

The 4 drum in-line pallet can store the drums against walls, opening up important usable floor space

The 6 and 8 drum units provide for added storage capability and easier access to your drums

Redesigned polyethylene construction for excellent chemical resistance

New flat top grading



MODEL # 1688
8 DRUM - 90 GALLON
SPILL CAPACITY
EXTERIOR DIMENSIONS
(102 X 51 1/2 X 6 1/2)"



MODEL#	DESCRIPTION	DIMENSIONS	WEIGHT	LOAD CAPACITY
1647	4 DRUM IN-LINE SPILL PLATFORM	106" X 30 1/4" X 6 3/4"	74 LBS.	8,000 LBS.
1686	6 DRUM PALLET UNIT-LOW PROFILE	77" X 51 1/2" X 6 1/2"	88 LBS.	8,000 LBS.
1688	8 DRUM PALLET UNIT-LOW PROFILE	102" X 51 1/2" X 6 1/2"	116 LBS.	10,000 LBS.
1689	POLY RAMP FOR 1647, 1686, 1688	45 1/2" X 32" X 8"	32 LBS.	1,500 LBS.
1689BLK	BLACK POLY RAMP FOR 1647, 1686, 1688	45 1/2" X 32" X 8"	32 LBS.	1,500 LBS.



MODEL # 1647
4 DRUM - 66 GALLON
SPILL CAPACITY
EXTERIOR DIMENSIONS
(H X W X D)
(106 X 30 1/4 X 6 3/4)"

NEW Design!



MODEL #1686
6 DRUM - 66 GALLON
SPILL CAPACITY
EXTERIOR DIMENSIONS
(77 X 51 1/2 X 6 1/2)"



MODEL # 1689BLK
BLACK POLY RAMP
EXTERIOR DIMENSIONS
(45 1/2 X 32 X 8)"



Spill Containment Pallets

FEATURES

Polyethylene construction for excellent chemical resistance

Grating with 13/4" square opening that removes easily for cleaning

Forkliftable design with 3/4" drain plug

Model 1645 and 1646 are compatible with our Model 1689 ramp

Meet EPA requirements for secondary spill containment of hazardous materials (40 CFR 264.175)



MODEL # 1620
2 DRUM - 66 GALLON
SPILL CAPACITY
EXTERIOR DIMENSIONS
(51 X 26 1/4 X 15)"

NEW Design!

MODEL # 1644
PALLET TARP
EXTERIOR DIMENSIONS
(54X 54 X 40)"



MODEL # 1640
4 DRUM PALLET
120 GALLON SPILL CAPACITY
EXTERIOR DIMENSIONS
(51 1/2 X 51 1/2 X 13 1/2)"



MODEL#	DESCRIPTION	DIMENSIONS	WEIGHT	LOAD CAPACITY
1612	SINGLE DRUM UNIT	31" X 33"	30 LBS.	-
1620	2 DRUM PALLET UNIT	51" X 26 1/4" X 15"	48 LBS.	4,000 LBS.
1640	4 DRUM PALLET UNIT	51 1/2" X 51 1/2" X 18 1/2"	104 LBS.	8,000 LBS.
1645	4 DRUM PALLET UNIT-LOW PROFILE	51 1/2" X 51 1/2" X 10"	65 LBS.	8,000 LBS.
1646	4 DRUM NESTABLE PALLET	58 1/2" X 58 1/2" X 7 3/4"	65 LBS.	6,000 LBS.
1689	POLY RAMP FOR 1645 & 1646	45 1/2" X 32" X 8"	32 LBS.	1,500 LBS.
1689BLK	BLACK POLY RAMP FOR 1645 & 1646	45 1/2" X 32" X 8"	32 LBS.	1,500 LBS.
1698	SINGLE DRUM CONTAINMENT DOLLY	27 1/2" X 7"	30 LBS.	1,000 LBS.

MODEL # 1645
4 DRUM - 66 GALLON
SPILL CAPACITY
EXTERIOR DIMENSIONS
(51 1/2 X 51 1/2 X 10)"
LOW PROFILE



Single drum containment ideal for use as a spill containment unit, a mobile pumping station or waste collection station

With the addition of the 1698 drum dolly the drum can be easily moved for dispensing or collection

MODEL # 1612
SINGLE DRUM CONTAINMENT UNIT
W/OPTIONAL 1698 DOLLY
WITH 3" RUBBER CASTORS
65 GALLON SPILL CAPACITY





Horizontal Drum Stacking System, IBC Spill Units, Utility Tray

FEATURES

All components are 100% polyethylene for durable chemical resistance

Units are designed to interlock into spill pallet grating for stable drum storage

Shelf attaches easily and allows for filling more than one container at a time

Stackers let you double up on storage in the same floor space and the Double Stackers are forkliftable.

IBC Spill Units (below right) comes with 100% polyethylene containment tub and your choice metal or poly platform and features a 400 gallon secondary spill capacity.

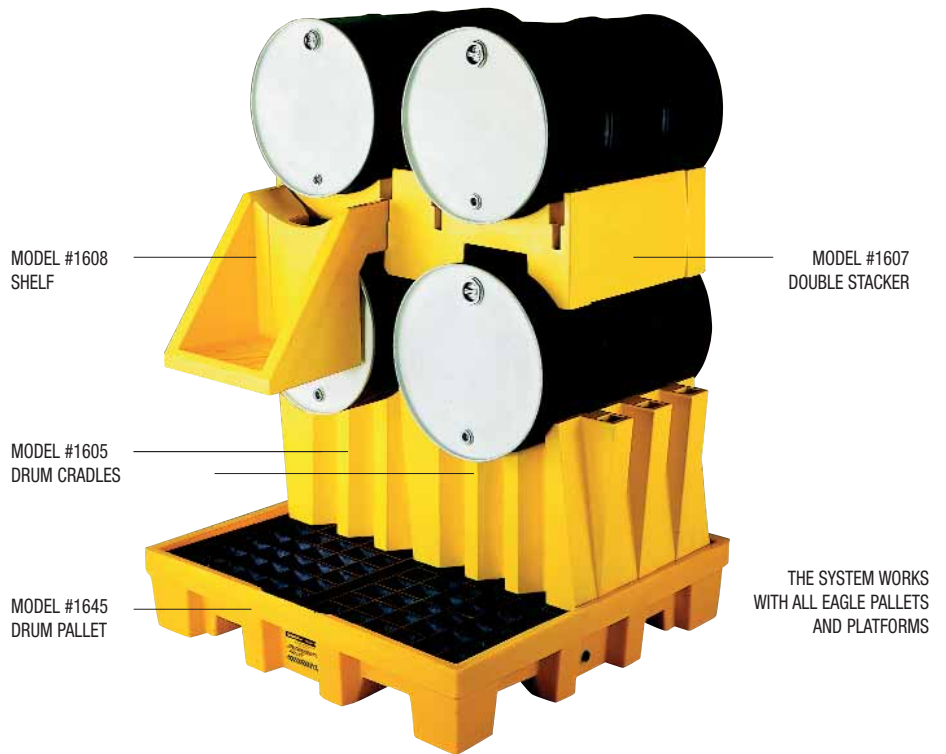

MODEL #1677
CONTAINMENT UTILITY TRAY
EXTERIOR DIMENSIONS
(18 X 36 X 2")

MODEL	DESCRIPTION	DIMENSIONS	WEIGHT	LOAD CAPACITY
1605	CRADLE*	29" X 26 1/2" X 22 1/2"	30 LBS.	2,000 LBS.
1606	SINGLE STACKER*	27" X 26 1/2" X 29"	30 LBS.	1,000 LBS.
1607	DOUBLE STACKER*	48" X 26 1/2" X 13"	30 LBS.	2,000 LBS.
1608	SHELF	19" X 23" X 19"	15 LBS.	100 LBS.
1680	IBC SPILL UNIT	67" X 67" X 26"	250 LBS.	10,000 LBS.
1683	IBC SPILL UNIT	67" X 67" X 26"	250 LBS.	10,000 LBS.
1684	IBC SPILL UNIT	118" X 77 1/2" X 20"	500 LBS.	20,000 LBS.
1958	HORIZONTAL DRUM LIFTER	-	5 LBS.	1,000 LBS.
1622	TWO DRUM PALLET TARP	52" X 27" X 41"	4 LBS.	-
1644	FOUR DRUM PALLET TARP	52" X 52" X 41"	6 LBS.	-
1677	CONTAINMENT UTILITY TRAY	18" X 36" X 2"	6 LBS.	-

* Fits all Eagle Spill Containment Platforms & Pallets



IBC Containment Units

Containment Utility Tray

An affordable way to contain small spills up to 5 gallons

Ideal for counter top use for the working storage of lab chemicals, as a drip pan under dispensers or as a floor tray under machinery

Ribbed bottom; nestable for easy storage

MODEL #1684
DOUBLE ALL POLY IBC
CONTAINMENT
EXTERIOR DIMENSIONS
(118 X 77 1/2 X 20")





Drum Bogie, Mobile Spill Platform and Drum Accessories

FEATURES

Mobile dispensing unit protects against incidental spills and leaks - for 30, 55 and 95 gallon drums

The durable polyethylene bogie resists corrosion, features a poly push-pull handle and 5 swivel casters for maximum stability, load capacity and maneuverability



MODEL #1660
DRUM FUNNEL

MODEL #1664
DRUM FUNNEL COVER

MODEL #1604C
SPILL PACK 80 ON CASTER SET



MODEL #1604
POLY SPILL PACK

MODEL #1603
SPILL PACK 40

MODEL #1670
DRIP PAN



MODEL #1613 DRUM BOGIE
1,250 LB. LOAD CAPACITY
HEIGHT 91/2"
FIVE 3" CASTERS
12 GALLON CAPACITY



MODEL #1637 MOBILE SPILL
PLATFORM
2,000 LB. LOAD CAPACITY
30 GALLON CAPACITY

MODEL#	DESCRIPTION	DIMENSIONS	WEIGHT
1603	40 GALLON POLY SPILL PACK	24" X 24" X 30"	30 LBS.
1603C	CASTER SET FOR 1603	-	10 LBS.
1604	80 GALLON POLY SPILL PACK	42" X 24" X 30"	60 LBS.
1604C	CASTER SET FOR 1604	-	12 LBS.
1613	DRUM BOGIE	353/4" X 42"	30 LBS.
1614	DRUM TRAY	31" X 6"	20 LBS.
1615	DRUM TRAY WITH GRATING	31" X 6"	24 LBS.
1618	DRUM TRAY DOLLY	31" X 7"	32 LBS.
1637	MOBILE SPILL CONTROL PLATFORM	28" X 56" X 41"	92 LBS.
1952	OVERPACK DOLLY	-	84 LBS.
1954	DRUM LIFTER	-	20 LBS.
1958	HORIZONTAL DRUM LIFTER	-	5 LBS.
1660	DRUM FUNNEL	18" X 7"	6.5 LBS.
1662	DRUM FUNNEL WITH SCREEN	18" X 7"	6.5 LBS.
1664	DRUM FUNNEL COVER	181/2" X 5"	1 LB.
1666	DRUM COVER - CLOSED HEAD	23" X 5"	2.5 LBS.
1667	DRUM COVER - OPEN HEAD	24" X 5"	2.5 LBS.
1670	DRIP PAN	101/2" X 101/2" X 3"	1 LB.
1698	OVERPACK DOLLY	271/2" X 7"	30 LBS.



MODEL #1614 MODEL #1618
OPTIONAL DRUM TRAY DOLLY
W/3" CASTERS
10 GALLON CAPACITY



MODEL #1952
OVER PACK DOLLY



MODEL #1954
DRUM LIFTER



MODEL #1958 DRUM LIFTER



MODEL #1666
DRUM COVER

MODEL #1667
DRUM COVER



RTC Pallet Unit, Work Stations and Outdoor Storage Buildings

FEATURES

Protect up to four 55-gallon drums from the elements with this rotary style hard cover pallet that features easy-lift pivot-point-axis design.

Height of protective cover allows storage with drum pumps in place. The cover secures to the low-profile pallet (7 3/4" H) at four points, two of which are lockable. 100% polyethylene construction resists corrosion, weathering, UV rays and is compatible with most aggressive chemicals.

Patented support grating is removable for easy cleaning of the 60-gallon sump. The pallet has a UDL load rating of 6000 lbs. and fits optional ramp Model 1689. Ships fully assembled.

Compliance: EPA 40 CFR 264.175



MODEL #1646RTC
ROTARY TOP CONTAINMENT UNIT
EXTERIOR DIMENSIONS
(59 1/2" X 73 1/2" X 68")



MODEL #1649
4 DRUM POLY STORAGE BUILDING
WITH OPTIONAL RAMP
EXTERIOR DIMENSIONS
(57 1/2" X 57 1/2" X 72")

DOOR OPENING
(50 5/8" X 49")



FEATURES

Securely store up to four 55 gallon drums, up to 8,000 lb. load capacity

Four-way forklift pockets, vented door louvers

66 gallon spill capacity

Removable grating and top hooks for moving

Usable with poly ramp (1689).

Compliance: EPA CFR 264.175.

New door size fits 48" x 48" pallet

Note: top hooks are intended only for moving an empty building

GRATING AVAILABLE FOR OTHER USES

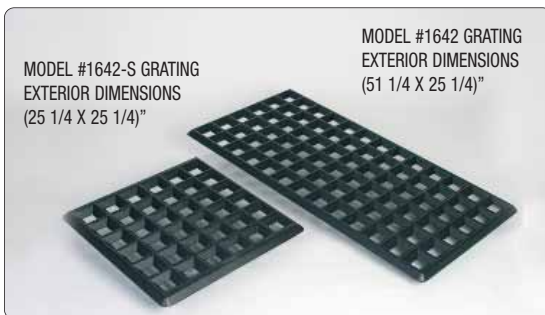

MODEL #1642-S GRATING
EXTERIOR DIMENSIONS
(25 1/4" X 25 1/4")

MODEL #1642 GRATING
EXTERIOR DIMENSIONS
(51 1/4" X 25 1/4")

MODEL#	DESCRIPTION	DIMENSIONS	WEIGHT
1626	2 DRUM WORKSTATION (LOW)	60" X 34" X 46"	100 LBS.
1628	2 DRUM WORKSTATION	60" X 34" X 64"	120 LBS.
1629	WORKSTATION DOLLY	6" X 60" X 34"	65 LBS.
1646RTC	ROTARY TOP CONTAINMENT UNIT	59 1/2" X 73 1/2" X 68"	290 LBS.
1649	4 DRUM POLY STORAGE BUILDING	57 1/2" X 57 1/2" X 72"	285 LBS.

FEATURES

Available in low (1626) or high (1628) profile for the storage of two drums

Forkliftable and optional dolly allows easier movement on worksite

Compliance: EPA 40 CFR 264.175.
EPA 40 CFR 264.175.

MODEL #1626
2-DRUM LOW-PROFILE WORKSTATION





Lab and Overpack Drums

FEATURES

The 14, 20 and 30 Gallon drums are available with plastic lids and your choice of metal or plastic lever locking bands

The 20, 30, 65 and 95 gallon drums are available with plastic screw-on lids

All Lab Packs and Overpacks are constructed of tough, chemical resistant high density polyethylene

Lightweight and nestable

Include UV inhibitors

The containers incinerate completely when used with the plastic lever locking or screw top

United Nations certified to HM-181

Can be used with packing groups I, II and III of hazardous materials

The overpacks feature a heavy duty metal lever locking band: ideal for the storage, transportation, clean up and spill containment of larger containers

The Lab Packs have either plastic lever locking band or screw top and are ideal for the storage, transportation, clean up and spill containment of small containers (5 gallons or less)

MODEL #1601
30 GALLON
EXTERIOR DIMENSIONS
(21 1/8 X 28 1/2)"

MODEL #1601MB
30 GALLON
EXTERIOR DIMENSIONS
(21 1/8 X 28 1/2)"

MODEL #1610MB
14 GALLON
EXTERIOR DIMENSIONS
(15 X 26 1/2)"



MODEL #1652
20 GALLON
EXTERIOR DIMENSIONS
(21 1/2 X 22)"

MODEL #1610
14 GALLON
EXTERIOR DIMENSIONS
(15 X 26 1/2)"

MODEL #1650
20 GALLON
EXTERIOR DIMENSIONS
(20 1/8 X 21 1/4)"

MODEL #1600SL
30 GALLON
EXTERIOR DIMENSIONS
(21 1/8 X 28 1/2)"

MODEL #1661
65 GALLON
EXTERIOR DIMENSIONS
(31 X 33 1/2)"

MODEL #1690
95 GALLON
EXTERIOR DIMENSIONS
(31 X 41 1/2)"



Compliance

Overpacks: DOT 49 CFR 173.25

Lab Packs: DOT 49 CFR 173.12

All drums meet FDA 21 CFR 177.1520

Food Grade Quality

LAB AND OVERPACK DRUMS						
MODEL#	SIZE	DESCRIPTION	DIMENSIONS	WEIGHT	UN MARKING	
1600SL	30 GALLON	LAB PACK W/SCREW LID	21 1/8" X 28 1/2"	14 LBS.	1H2/X120/S	1H2/Y180/S
1601	30 GALLON	LAB PACK W/PLASTIC BAND	21 1/8" X 28 1/2"	14 LBS.	1H2/X100/S	
1601M	30 GALLON	LAB PACK W/METAL BAND	21 1/8" X 28 1/2"	15 LBS.	1H2/X120/S	1H2/Y180/S
1601MB	30 GALLON	LAB PACK W/METAL BAND, BLUE	21 1/8" X 28 1/2"	15 LBS.	1H2/X120/S	1H2/Y180/S
1610	14 GALLON	LAB PACK W/PLASTIC BAND	15" X 26 1/2"	8 LBS.	1H2/X65/S	1H2/Y100/S
1610MB	14 GALLON	LAB PACK W/METAL BAND, BLUE	15" X 26 1/2"	8.5 LBS.	1H2/X65/S	1H2/Y100/S
1650	20 GALLON	LAB PACK W/SCREW LID	20 1/2" X 21 1/4"	13 LBS.	1H2/X57/S	
1652	20 GALLON	LAB PACK W/PLASTIC BAND	20 1/2" X 22"	13 LBS.	1H2/X40/S	
1661	65 GALLON	OVERPACK W/SCREW LID	31" X 33 1/2"	45 LBS.	1H2/X300/S	
1690	95 GALLON	OVERPACK W/SCREW LID	31" X 41 1/2"	50 LBS.	1H2/X300/S	



Salvage Drums

FEATURES

Available in 20, 30, 65 and 95 gallon sizes

Constructed of blow molded high density polyethylene with UV inhibitors

The 1602 and 1654 drums are suitable for 5 gallon buckets and smaller

The 1665 and 1695 are for 55 gallon drums or smaller

All Salvage Drums meet 3 psi pressure test for Salvage Drum Compliance

The lids feature gaskets for a positive seal with locking band

Ideal for secondary containment storage, transportation and cleanup.

Compliance: DOT 49 CFR 173.3



SALVAGE DRUMS						
MODEL#	SIZE	DESCRIPTION	DIMENSIONS	WEIGHT	UN MARKING	
1602	30 GALLON	SALVAGE W/METAL BAND	21 1/8" X 28 1/2"	16 LBS.	1H2/X100/S	
1654	20 GALLON	SALVAGE W/METAL BAND	22" X 20 1/2"	15 LBS.	1H2/X75/S	
1665	65 GALLON	SALVAGE W/METAL BAND	31" X 39"	53 LBS.	1H2/X200/S	
1695	95 GALLON	SALVAGE W/METAL BAND	31" X 44 1/2"	58 LBS.	1H2/X340/S	



Spill-Gun Emergency Spill Control Applicators

FEATURES

The easiest, fastest, and most efficient method to handle a small to medium chemical spill before it becomes a big problem.

Spill Guns

Rugged easy-to-use, rechargeable in the field

Available in acid, caustic, or solvent Spill-X agents

Designed to apply the agent from a safe distance of 10 to 12 feet

The spill gun can treat up to a 3 gallon spill (equivalent to approximately 100 square feet)

Spill-X Agents

SPILL-X-A agent neutralizes and solidifies most organic and inorganic acids, including hydrofluoric acid.

SPILL-X-S agent is a solvent absorbent for organic materials like benzene or xylene.

SPILL-X-C agent is a neutralizer and solidifier for caustics such as sodium hydroxide.

SPILL-X-FP agent polymerizes and solidifies formaldehyde spills.

Recharge Chemical and Spill Treatment kits also available



MODEL#	DESCRIPTION	WEIGHT
SC-30-A	30LB ACID NEUTRALIZER SPILL APPLICATOR GUN	58LB (26.3 KG)
SC-30-C	30LB CAUSTIC NEUTRALIZER SPILL APPLICATOR GUN	53LB (24.0 KG)
SC-30-S	30LB SOLVENT ABSORBENT SPILL APPLICATOR GUN	43LB (19.5 KG)



Universal & Oil Spill Kits

Oil kits are designed to handle oil & fuel spills on land and water.

Universal Kits are designed to handle caustics, common fluids such as coolant spills ethanol, pesticides as well as solvents.

Our Spill kits are available in a variety of sizes to meet all your requirements.

NEW Product!

POLY DOLLY 1698

With the addition of model 1698 larger 45 & 65 gallon Spill Kits can easily be moved for emergency spill containment.



HWUSK-65 UNIVERSAL	
QTY	DESCRIPTION
50	Sorbent Pads - 17" x 19" x 3/8"
5	Sorbent Socks - 3" x 4'
5	Sorbent Pillows - 8" x 18"
4	Boom - 5" x 10'
1	Sorbent Roll - 15" x 150'
1	Drain Cover - 36" x 36" x 1/16"
1	Caution Tape - 3" x 500'
2	Pair Nitrile Gloves
2	Pair Goggles
10	Disposal Bags - 26" x 36"
2	Tyvek Coveralls
1	Gallon/275 Litre
1	95 Gallon Poly Overpack Drum
RK-65-U, Refill	

65 GALLON

HWOSK-65 OIL	
QTY	DESCRIPTION
50	Sorbent pads - 17" x 19"
5	Sorbent Socks - 3" x 48"
5	Sorbent Pillows 8" x 18"
4	Boom - 15" x 10"
1	Sorbent Roll - 15" x 150'
1	Drain Cover - 36" 36" x 1/16"
1	Caution Tape - 3" x 500'
1	Repair Putty
2	Pair Safety Goggles
2	Pair Nitrile Gloves
10	Disposal Bag - 26" x 26"
2	Tyvek Coveralls
1	95 Gallon Poly Overpack Drum
RK-65-O, Refill	

65 GALLON

HWUSK-45 UNIVERSAL	
QTY	DESCRIPTION
50	Sorbent Pads
3	Sorbent Socks 3' x 120"
5	Sorbent Socks 3" x 48"
1	Neoprene Drain Cover
3	Disposal Bags
1	Pair Safety Goggles
1	Pair Nitrile Gloves
2	Tyvek Suits
1	65 Gallon Poly Overpack Drum
RK-45-U, Refill	

45 GALLON

HWOSK-45 OIL	
QTY	DESCRIPTION
50	Sorbent Pads -
3	Sorbent Socks - 3" x 120"
5	Sorbent Socks - 3" x 48"
1	Neoprene Bag
3	Disposal Bags
1	Pair Safety Goggles
1	Pair Nitrile Gloves
2	Tyvek Suits
1	65 Gallon Poly Overpack Drum
RK-45-O, Refill	

45 GALLON

HWUSK-30 UNIVERSAL	
QTY	DESCRIPTION
50	Sorbent pads - 17" x 19"
6	Sorbent Socks - 3" x 48"
4	Sorbent Pillows 8" x 18"
1	Pair Safety Goggles
1	Pair Nitrile Gloves
1	Disposal Bag
1	1600SL 30 Gallon Overpack Drum
RK-30-U, Refill	

30 GALLON

HWOSK-30 OIL	
QTY	DESCRIPTION
50	Sorbent pads - 17" x 19"
12	Sorbent Socks - 3" x 48"
4	Sorbent Pillows 8" x 18"
1	Pair Safety Goggles
1	Pair Nitrile Gloves
1	Disposal Bag
1	1600SL 30 Gallon Overpack Drum
RK-30-O, Refill	

30 GALLON

HWUSK-20 UNIVERSAL	
QTY	DESCRIPTION
4	Sorbent Socks - 3" x 10'
75	Sorbent Sheet
1	Drain Cover - 36" x 36" x 1/16"
1	Caution Tape - 3" x 500'
2	Pair Nitrile Gloves
2	Pair Goggles
2	Tyvek Coveralls
5	Disposal Bags - 26" x 30"
1	1650 Lab Pack Poly Drum
RK-20-U, Refill	

20 GALLON

HWOSK-20 OIL	
QTY	DESCRIPTION
50	Sorbent Pads - 17" x 19" x 3/16"
4	Sorbent Socks - 3" x 120"
1	Drain Cover - 36" x 36"
1	Repair Putty
2	Pair Nitrile Gloves
5	Disposal Bags - 26" x 36"
1	1650 Lab Pack Poly Drum
RK-20-O, Refill	

20 GALLON

Vehicle & Specialty Spill Kits

HWOSK-10P OIL	
QTY	DESCRIPTION
20	Sorbent Pads - 17" x 19"
3	Sorbent Socks - 3" x 48"
2	Sorbent Pillows - 8" x 18"
2	Disposal bags
1	Pair Nitrile Gloves
1	Pair safety Goggles
1	14Gal. Pail
RK-10-O, Refill	

HWUSK-10P UNIVERSAL	
QTY	DESCRIPTION
20	Sorbent Pads - 17" x 19"
3	Sorbent Socks - 3" x 48"
2	Sorbent Pillows - 8" x 18"
2	Disposal Bags
1	Pair Nitrile Gloves
1	Pair Safety Goggles
1	14gal. Pail
RK-10-U, Refill	

HWUSK-10N UNIVERSAL	
QTY	DESCRIPTION
20	Sorbent Pads - 17" x 19"
3	Sorbent Socks - 3" x 48"
2	Sorbent Pillows 8" x 18"
1	Pair Safety Goggles
1	Pair Nitrile Gloves
2	Disposal Bag
1	Nylon Bag
RK-10-U, Replacement Kit	

HWOSK-10N OIL	
QTY	DESCRIPTION
20	Sorbent Pads - 17" x 19"
3	Sorbent Socks - 3" x 48"
2	Sorbent Pillows - 8" x 18"
2	Disposal bags
1	Pair Nitrile Gloves
1	Pair Safety Goggles
1	Nylon Bag
RK-10-O, Replacement Kit	

HWASK ACID KIT	
QTY	DESCRIPTION
4	4kg ACD Powder Neutralizer with Colour Indicator
2	Sobent Socks
35	Sorbent Pads
2	Pair Safety goggles
2	Pair Nitrile Gloves
5	Diposal Bags
2	Tyvek Suits
1	Instruction Guide
1	20 Gallon Labpack

HWBSK BATTERY KIT	
QTY	DESCRIPTION
4	4kg Hazkleen ACD Powder Neutralizer with Colour Indicator
3	Universal Sobent Pads
20	Universal Sorbent Socks
2	Pair Nitrile Gloves
2	Pair Safety Goggles
3	Disposal Bags
2	Tyvek Suits
1	Instruction Guide
1	20 Gallon Labpack

HWCSK CAUSTIC	
QTY	DESCRIPTION
8	1kg Hazkleen CST Powder Neutralizer with Colour Indicator
15	Universal Sobent Pads
2	Universal Sorbent Socks
2	Pair Nitrile Gloves
2	Pair Safety Goggles
3	Disposal Bags
2	Tyvek Suits
1	Instruction Guide
1	20 Gallon Labpack

HWUSK-10 UNIVERSAL	
QTY	DESCRIPTION
20	Sorbent Pads - 17" x 19"
3	Sorbent Socks - 3" x 48"
2	Sorbent Pillows 8" x 18"
1	Pair Safety Goggles
1	Pair Nitrile Gloves
2	Disposal Bag
1	Poly Zipper Bag
RK-10-U, Replacement Kit	

HWOSK-10 OIL	
QTY	DESCRIPTION
20	Sorbent Pads - 17" x 19"
3	Sorbent Socks - 3" x 48"
2	Sorbent Pillows - 8" x 18"
2	Disposal Bags
1	Pair Nitrile Gloves
1	Pair Safety Goggles
1	Poly Zipper Bag
RK-10-O, Replacement Kit	

NEW Product!

CAUSTIC SPILL KITS

Contain sufficient material to neutralize and absorb up to 15 litres of highly concentrated caustic liquid.

ACID SPILL KITS

Contain sufficient material to neutralize and absorb up to 10 litres of Various concentrated acid.

BATTERY SPILL KITS

Contain sufficient material to neutralize and absorb up to 32 litres of battery acid.



HWUSK-10N



HWUSK-10

